

## TOLLGATE BILLING AND SECURITY OF VEHICLE USING RFID

**SAGAR MUPPALLA \*1,**

Research Scholar

ECM Department

K L University

A.P., India

**G.RAJESH CHANDRA\*2,**

Assistant professor

ECM Department

K L University

A.P., India

**N.RAJESH BABU\*3**

Assistant Professor

ECM Department

K L University

A.P., India

### ABSTRACT

This paper deals with an improved form of tollgate billing system. An efficient utilization of communication link between RF Modems over a wireless channel to facilitate vehicle monitoring, vehicle authentication and automated toll collection on the highways is proposed. The system is implemented to automatically register vehicles getting on or off a motorway or highway, cutting the amount of time for paying toll in large queues. In this we are using active RFID tag. Which takes power supply from vehicle battery itself? Mainly concentrate on the security of the vehicle and authentication process whether the driver is correct person or not to use the vehicle. In this paper we are proposing 3 solutions for authentication of vehicle. They are

1. GSM technology
2. Using finger prints
3. Password through passive RFID technology

**Keywords:** Tollgate billing, RFID, Authentication, GSM.

### Introduction:

This paper deals with an improved form of tollgate billing system. Mainly concentrate on the security of the vehicle and authentication process whether the driver is correct person or not to use the vehicle It contains two modules Base module, and vehicle module. The base continuously transmits an interrogation message over its range so that if any vehicle enters the range it must get registered with the base. The vehicle module receives the interrogation message and sends the data stored in microcontroller (Registration Number, Chassis Number, Engine Number, Owner's Name and Make of the vehicle etc). The base receives the data from the vehicle and checks whether the data is valid. Then it registers the vehicle and sends an authentication message to the vehicle. The vehicle module receives the authentication and goes into a wait loop till the time it reaches the barrier and sends its notification message. The vehicle identifies the toll collection centre. It sends its specific notification message to the base to update its data base for billing purposes. The base receives that

specific message and opens the barrier after authenticating that the vehicle passing by is a valid one. The base will never open the gate for invalid or unregistered vehicle. If such a vehicle approaches the gate, the base would detect it and trigger an alarm for security purposes. In this paper we are proposing 3 solutions for authentication of vehicle. They are

1. GSM technology
2. Using finger prints
3. Password through passive RFID technology

### Existing Technologies

Active wave Inc [3] has currently deployed a system of active tag vehicle monitoring solution. Active wave vehicle products have a range of 30 meters and operate in the 916 – 927 MHz for the transmit operations and 433 MHz for the receive link. Active wave products are currently equipped with 256 Kbits of fixed memory. The tag is powered with a replaceable 3V battery and the total weight is 14 grams. Elementary signals are shown with the help of blinking LEDs and beeping sounds. Smart key Access Control Systems [4] have a client – server model based system with an SQL server handling multiple vehicle monitoring systems. They have designed a user interface using the Microsoft .NET Framework. Smart key also operate in the 900MHz band but have a small range of 30 meters. *RFID based toll collection system*[1] uses active RFID tag which uses car battery power. The implementation is divided into the design of two modules- the Vehicle Module (Active Tag) and the Base Module. The two modules communicate via RF modem connected to each module. These RF modules communicate over the ISM Frequency Range of 902 – 928 MHz.

### Limitations of Currently Available Technologies:

The previously discussed technologies face a number of problems that this project aims to address. All the currently available technologies face poor authentication problems and small battery power. And authentication is through GSM technology. Vehicle Module is designed to operate on the vehicle's own battery so that no separate battery supply is required [1]. This would reduce the recurring costs and the need of maintenance. Vehicle Module compensates for the

high power during transmit mode by using the low power sleep modes when not in range of the Base Module.

**RFID TECHNOLOGY:**

**A. RFID TAGS:**

RFID tags come in three general varieties:- passive, active, or semi-passive (also known as battery-assisted)[5]. Passive tags require no internal power source, thus being pure passive devices (they are only active when a reader is nearby to power them), whereas semi-passive and active tags require a power source, usually a small battery. Passive RFID tags have no internal power supply. The minute electrical current induced in the antenna by the incoming radio frequency signal provides just enough power for the CMOS integrated circuit in the tag to power up and transmit a response. Most passive tags signal by backscattering the carrier wave from the reader. Unlike passive RFID tags, active RFID tags have their own internal power source, which is used to power the integrated circuits and broadcast the signal to the reader. Active tags are typically much more reliable (i.e. fewer errors) than passive tags unlike passive RFID tags, active RFID tags have their own internal power source, which is used to power the integrated circuits and broadcast the signal to the reader. Active tags are typically much more reliable (i.e. fewer errors) than passive tags To communicate, tags respond to queries generating signals that must not create interference with the readers, as arriving signals can be very weak and must be told apart. Besides backscattering, load modulation techniques can be used to manipulate the reader's field. Typically, backscatter is used in the far field, whereas load modulation applies in the near field, within a few wavelengths from the reader.

**B. RFID Reader:**

RFID reader is the device which is used to convert the received radio signals of a particular frequency into the digital form for the usage by the controller and PC. This reader has on-chip power supply. It incorporates energy-transfer circuit to supply the transponder.

**PROCEDURE**

**A. Base Module:**

The Base Module is installed at the entry points of highway near the barriers of Toll Plazas. The function of the base module is to register the vehicles in its range, allow them to pass if the vehicles are valid and trigger the alarms in case of invalid vehicles.

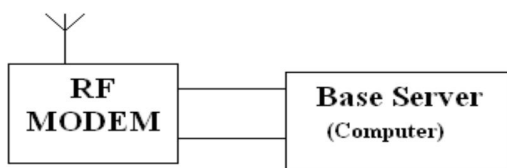

Figure 1. Base Module

The base station computer is programmed to continuously send an interrogation over its range. In case of any response to the interrogation message, if the base computer receives any vehicle data, it compares the data with the pre-saved data in its database. If the vehicle is allowed to pass, the base sends an authentication message to the vehicle module. The purpose of the authentication message is to counter erroneous transmission of data identify the thieves. Another feature that is installed in the base station is to accept chat requests once a vehicle in range has been registered. This can be used to inform the base station personnel if help is needed or for any sort of feedback. The base station can also send short messages in the chat area to the vehicle. This is useful for sending out broadcasts or other road related warnings. Users will also be able to access data related to vehicles in range, such as registration number, engine number, owner's name, and even a picture of the registered vehicle if implemented. These features will enable to combat theft and unauthorized use of the vehicle modules. The usage of the user interface is designed to be simple yet functional. The learning curve for the program is short and any new user will find their way intuitively.

**B. Vehicle Module:**

The vehicle module is installed in the vehicle. When the vehicle enters in the range of base, it receives the interrogation message and it replies it with its stored data.

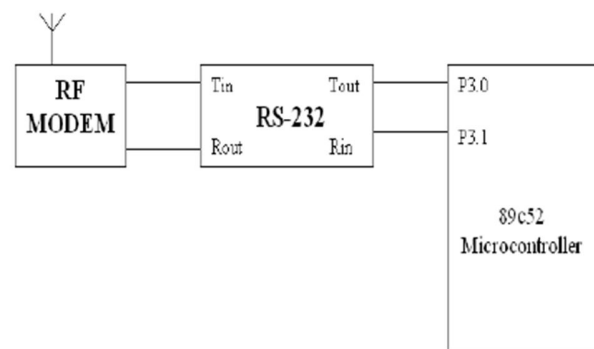

Figure2. Vehicle module

The vehicle module uses 8051 microcontroller [6]. The microcontroller contains the data of the vehicle in which it is installed. The vehicle data consists of registration number, chassis number, engine number, or owner's name etc. MAX-232 IC converts voltage levels to and from +5V and +9V. It is placed between microcontroller and RF modem. Microcontroller operates at +5V whereas RF modem communicates through serial port at +9V. So there is a need to convert the signal levels going through RF modem to microcontroller and vice versa. Data coming through RF modem is converted from +9V to +5V. Similarly data coming through microcontroller is converted from +5V to

+9V. The RF modem communicates with base via a wireless channel. It operates in ISM 900MHz band. The modulation scheme used is Frequency Hopping Spread Spectrum.

### AUTHENTICATION MODELS

#### 1. Using GSM technology:

This contains three modules. One is base module, vehicle module, and home module. The base module is equipped with RFID reader, server which contains customer details and GSM transceiver. The vehicle module is equipped with active RFID tag, keyboard, LCD display. Third module is home module contains GSM transceiver and two modes ON mode, OFF mode indicates always allow the vehicle to pass through tollgate. OFF mode indicates always stop the vehicle.

The base continuously transmits an interrogation message over its range so that if any vehicle enters the range it must get registered with the base. The vehicle module receives the interrogation message and sends the data stored in microcontroller (Registration Number, Chassis Number, Engine Number, Owner's Name and Make of the vehicle etc). The base receives the data from the vehicle and checks whether the data is valid. If the information is correct it checks whether the home module is in on position or off position through the GSM transceiver. If it is in on position it collects money from his account, if it is in off position the vehicle must be stopped.

The reason why we are including home module is to identify thieves. While going out the owner must keep this module in on position. If he lost his vehicle then he puts home module in OFF mode. Then the tollgate operators will stop the vehicle and arrest the person who drives the vehicle.

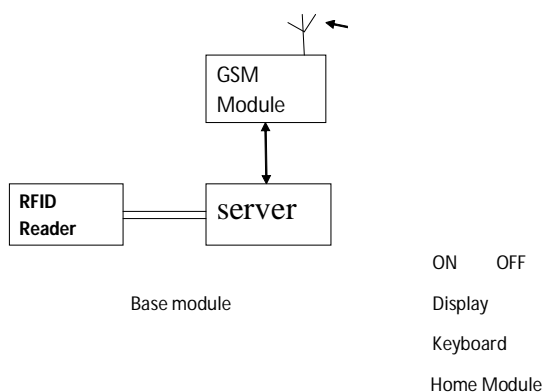

Figure 3. Authentication through GSM

#### 2. Using finger print recognition system:

At the time of allocating active RFID tag to the vehicle at tollgate office they will take the finger prints of

4 or 5 numbers who will drive the vehicle in the future. And we place a finger print recognizer inside the car, which is connected to the active RFID tag. These details such as vehicle no, engine no, account number, and finger prints of authorized persons are stored in server connected to base module. When the base module sends the authentication message to the vehicle module, the vehicle module receives this message. Now the driver puts his finger on already equipped finger print recognizer. It recognize the finger print and send to the base module through active RFID tag. The base module receives this information and compares this finger print with pre saved finger prints in the server. If it is not matched with the finger prints in the server the gates remains closed. And the buzzer makes sound.

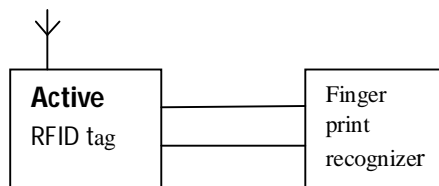

Figure 4: vehicle module

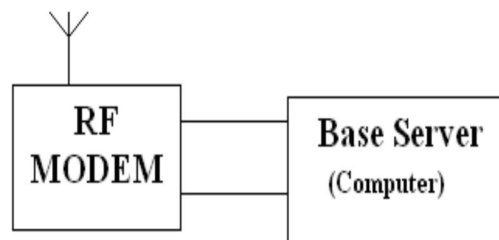

Figure 5: base module

#### 3. Using Passive RFID technology:

Another technique for authentication is typing password in the vehicle module. Typing password is very difficult at the time of driving. So we are going for new solution. That is by using passive RFID technology. At the time of fitting active RFID tag at the top of the car we also fit one passive RFID tag and passive RFID reader inside the car. This passive RFID tag contains password. When the base module sends the authentication message to the vehicle module, the vehicle module receives this message. Now the driver puts passive RFID tag near to the reader and communication exist between passive RFID tag and reader. Passive RFID reader this password and sent to the base module through active RFID tag. The base module receives this password and compares this password with pre saved password in the server. If it is not matched with the password in the server the gate remains closed. And the buzzer makes sound.

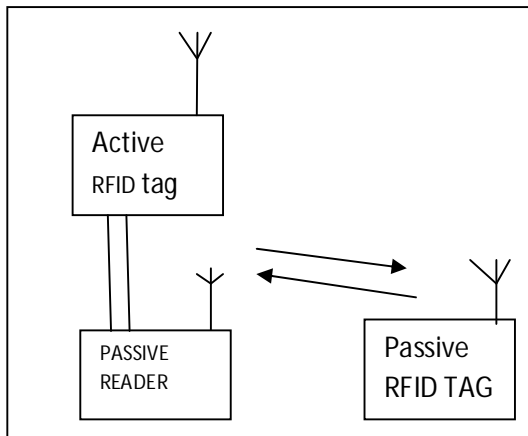

Figure 6: vehicle module

**Conclusion:**

In this paper proposed tollgate billing process and authentication process by using three different solutions. Out of these three authentication models authentication through GSM technology and passive RFID are the best solutions to identify the theft vehicles. Where as in finger print recognition system we may encounter some problems.

**REFERENCES:**

- [1] RFID based toll collection system,2011 IEEE third international conference
- [2] Yoon, W.J.; Chung, S.H.; Lee, S.J, "Implementation and performance evaluation of an active RFID system for fast tag collection," Computer Communications, 2008, vol. 31, pp. 4107-4116.
- [3] Active Wave Inc. <http://www.activewaveinc.com>
- [4] Smart key Access Control System <http://www.smartkey-rfid.com>
- [5] [http://en.wikipedia.org/wiki/Radio-frequency\\_identification](http://en.wikipedia.org/wiki/Radio-frequency_identification)
- [6] James W. STEWART, "The 8051 microcontroller: Hardware, software and interfacing" - by; Prentice Hall, Englewood Cliffs, NJ, USA; 1993; 273 pp.; ISBN: 0-13-584046-5
- [7] <http://en.wikipedia.org/wiki/GSM>